



Size Range 239,5 x 85 mm 9,43 x 3,35 "
AC HIGH PERFORMANCES AXIAL FAN

TECHNICAL DATA

Characteristics

- Weight: 3,85Kg/8,51 Lb (61GS) ; 4,25 Kg/9,39 Lb (61GP et 61GE)
- Housing in Aluminium
- Impeller in plastic
- L-10 life expectancy at 40°C: 25.000 hours
- Operating temperature range: -10 / +70 °C
- Storage temperature: -54 / +85°C
- Connection: Leads
- IP40

Options

- Speed sensor
- Other IP levels
- Terminal connection
- Salt spray protection
- Shocks and vibrations protection
- Marine application
- Wide temperature range
- Other voltages
- Safety switch
- Terminal block
- NATO Codification (not on all part numbers, please consult the factory for more detailed information)

ELECTRICAL AND AERAILIC DATA

Part Number	Voltage Frequency		Nb Phases	Airflow		Pressure		Nominal speed RPM	Noise level LP dBA	Nominal current A	power W	Capacitor µF
	V	Hz		l/s	CFM	mm H ₂ O	inch H ₂ O					
61GS016DC13 A	230	50	3	96,50	204,58	8,16	0,32	1480	57	0,15	27,00	
	400	50	3	96,50	204,58	8,16	0,32	1480	57	0,09	26,00	
	230	60	3	116,50	246,98	11,73	0,46	1770	60	0,13	24,00	
	400	60	3	116,50	246,98	11,73	0,46	1770	60	0,07	24,00	
	230	50	1	96,50	204,58	8,16	0,32	1480	57	0,15	20,00	1,47
	400	50	1	96,50	204,58	8,16	0,32	1480	57			0,47
	230	60	1	116,50	246,98	11,73	0,46	1770	60	0,12	22,00	1,47
	400	60	1	116,50	246,98	11,73	0,46	1770	60			0,47
61GP016DC13 A	230	50	3	240,30	509,44	34,16	1,34	2870	71	0,29	67,50	
	400	50	3	240,30	509,44	34,16	1,34	2870	71	0,17	65,70	
	230	50	1	240,30	509,44	34,16	1,34	2870	71	0,33	71,00	4,70
	400	50	1	240,30	509,44	34,16	1,34	2870	71	0,19	70,00	1,47
61GE016DC13 A	230	60	3	294,00	623,28	46,91	1,85	3400	74	0,41	110,00	
	400	60	3	294,00	623,28	46,91	1,85	3400	74	0,24	110,00	
	230	60	1	294,00	623,28	46,91	1,85	3400	74	0,51	113,00	4,70
	400	60	1	294,00	623,28	46,91	1,85	3400	74	0,30	113,00	1,47

DRAWING AND AIRFLOW CURVE

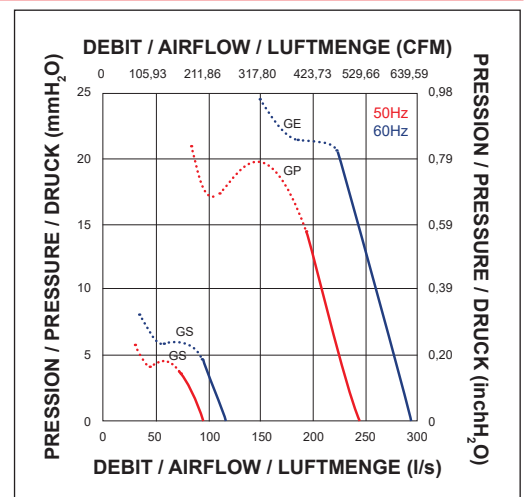
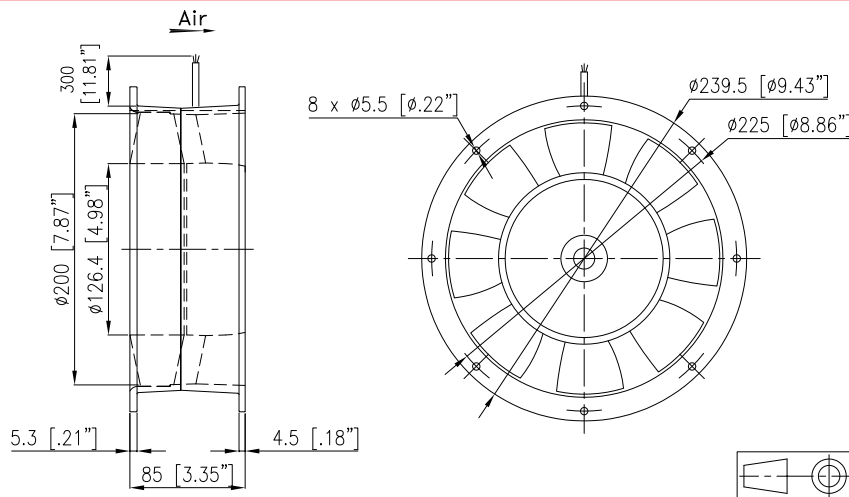

Non contractual document. All specifications are subject to change without prior notice. For professional use only. Please refer to the conditions of use of our catalogue.