



Size Range 92 x 92 x 25 mm
AC AXIAL FAN

3,62 x 3,62 x 1 "

TECHNICAL DATA

Characteristics

- Weight: 0,395 Kg / 0,87 Lb
- Housing in ZAMAK
- Impeller in plastic UL 94 V-0
- L-10 life expectancy at 40°C: 80.000 hours
- Operating temperature range: -10 / +70 °C
- Storage temperature: -54 / +85°C
- Connection: Terminals
- Impedance protected
- IP20

Options

- Speed sensor
- Other IP levels
- Flying leads connection
- Salt spray protection
- Shocks and vibrations protection
- Marine application
- Wide temperature range
- Other voltages

ELECTRICAL AND AERAILIC DATA

Part Number	Voltage Frequency		Nb Phases	Airflow		Pressure		Nominal speed RPM	Noise level LP dBA	Nominal current mA	Starting current mA	power W	Capacitor μF
	V	Hz		l/s	CFM	mm H ₂ O	inch H ₂ O						
99XM0182001	115	50	1	8,00	16,96	1,60	0,06	1500	21	75	80	7,00	
	115	60	1	10,00	21,20	2,40	0,09	1800	26	65	70	6,00	
99XM0181001	220	50	1	8,00	16,96	1,60	0,06	1500	21	40	45	8,00	
	220	60	1	10,00	21,20	2,40	0,09	1800	26	35	40	7,00	
99XW0182001	115	50	1	12,00	25,44	3,80	0,15	2200	32	85	100	8,00	
	115	60	1	14,00	29,68	4,80	0,19	2500	36	70	90	6,00	
99XW0181001	220	50	1	12,00	25,44	3,80	0,15	2200	32	50	60	9,00	
	220	60	1	14,00	29,68	4,80	0,19	2500	36	40	50	7,00	
99XU0182001	115	50	1	15,00	31,80	6,00	0,24	2700	38	135	200	12,00	
	115	60	1	18,50	39,22	8,50	0,33	3200	42	105	180	9,00	
99XU0181001	220	50	1	15,00	31,80	6,00	0,24	2700	38	70	100	14,00	
	220	60	1	18,50	39,22	8,50	0,33	3200	42	60	90	11,00	

DRAWING AND AIRFLOW CURVE

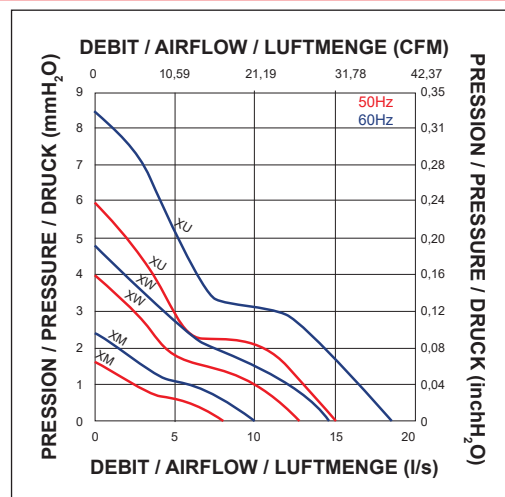
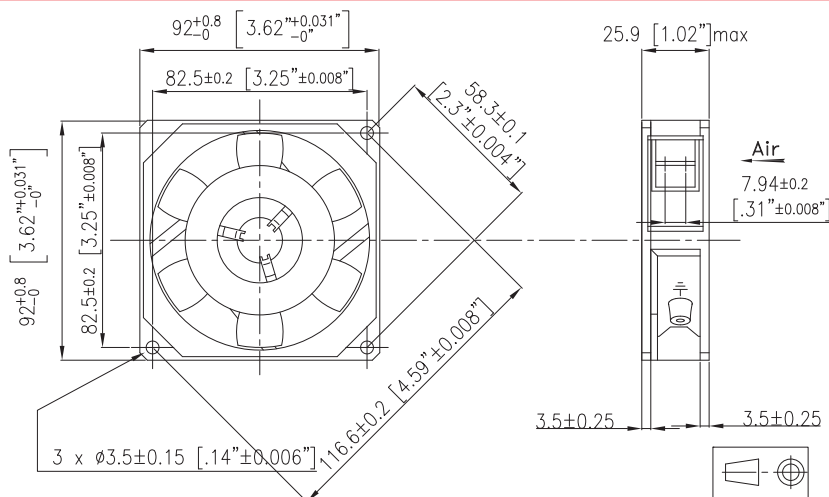

Non contractual document. All specifications are subject to change without prior notice. For professional use only. Please refer to the conditions of use of our catalogue.