

Technical guide

EC300 motor – V8

I

15/11/2016

1st release



Electrical installation

230V version :

Parameter	Min.	Nominal/Type	Max.	Unit	Remarks
Motor Class I					
Power supply					
Voltage (recommended)	200	220..230	277	Vac	
Voltage (maximum)	174		293	Vac	
Frequency	48	50	65	Hz	
Power usage	1	1..300	300	W	
Gauge					Dedicated connector on request
CE type	0.5mm ² / Ø0.813mm				
UL type	0.596mm ² / Ø1.02mm / 20AWG				

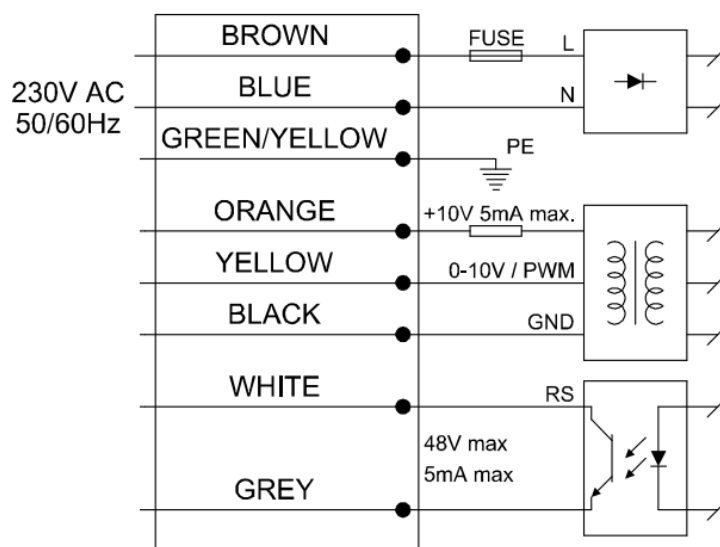

The EC300 motor is a class I product which means connection to protective earth is mandatory to comply with safety regulation.

In general, installation should take care to not have power cables and interface cables laying next to each other, perpendicular crossing should be preferred.

While the motor is powered ON, do not connect Vctrl (yellow wire : 0-10V / PWM) to an external controller before GND (black wire) is connected.



The V8 motor-fan contains electronic device which can be sensitive to electrostatic discharge. Take appropriate care especially when handling the low voltage cable.

Analog input and outputs

Inputs :

Parameter	Min.	Nominal/Type	Max.	Unit	Remarks
Input 0-10V/PWM					
Input resistance		100K		Ohms	
0-10V option					
Voltage range	0		10	Vdc	
Full stop voltage	0.7	1		Vdc	
Minimum speed voltage		1	1.3	Vdc	
Maximum speed voltage	9.9	10	10.1	Vdc	
Resolution		8		Bits	
PWM option					
Voltage range	0		10	Vdc	PWM must be at 0V and 10V (low and high states)
Frequency range	1000		10000	Hz	
PWM range	0		100	%	
Resolution		8		bits	

Parameter	Min.	Nominal/Type	Max.	Unit	Remarks
Power consumption					
Motor not running (Vctrl=0V)		0.95	1.1	W	Under 230V

Outputs :

Parameter	Min.	Nominal/Type	Max.	Unit	Remarks
+10V isolated					
Output current		5		mA	Short circuit-protected.
Opto Type		NPN type OC			OC=Open Collector
External voltage range	1		48	Vdc	
External current range			5	mA	
Frequency range	1		60	Hz	60Hz = 3600 RPM
Vcesat		0.25	0.4	Vdc	

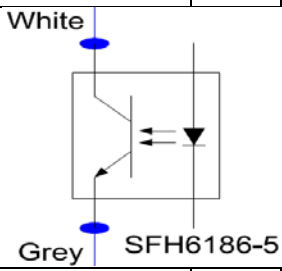
Parameter	Min.	Nominal/Type	Max.	Unit	Remarks
Opto type					
Wiring convention		 <p>White</p> <p>Grey SFH6186-5</p>			Other cable color on specific request
Gauge					Dedicated connector on request
CE type		0.22mm ² / Ø0.61mm			
UL type		0.343mm ² / Ø0.76mm / 22AWG			
Configured to Tachymeter					
Duty Cycle		50%			60Hz = 3600 RPM
Configured to Alarm		Normally 'Open' Or 'Closed'			

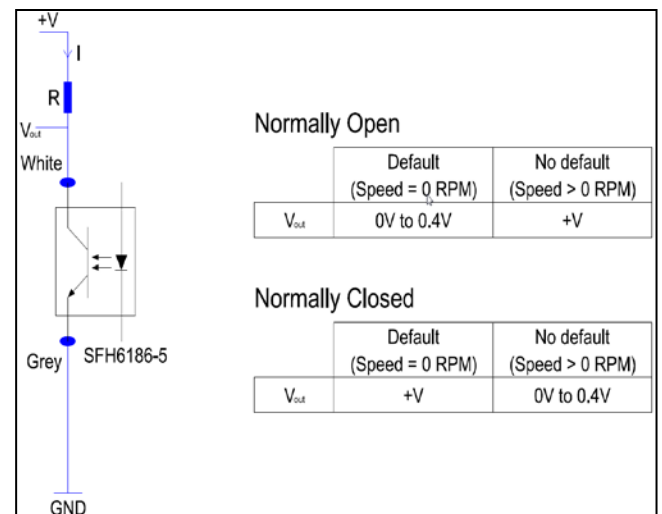
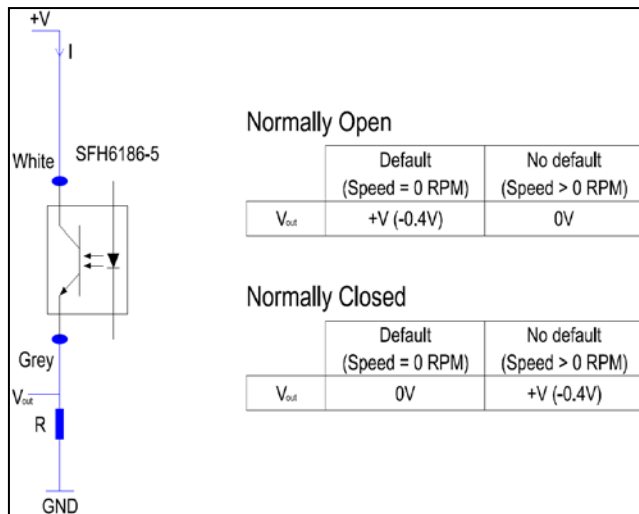

Additional protection

If the motor is connected to an electric installation where an earth leakage circuit breaker is used as additional protection, this circuit breaker must be of the type A or B according to EN50178. Leakage current measured according to EN60335 is less than 3.5mA.

Product safety behavior

Blocked rotor:

The electronic driver detecting a blocked rotor will power off the motor. Every 5s, it will try to restart, up to 25 times.

If none of the attempts succeed, the motor will go into a safety mode. It will be necessary to power OFF the motor for about 1 minute to reinitialize and to check if the rotor is rotating freely.

Motor overload:

In case of overload condition detected by the electronic driver (too high current or too high speed), it will stop powering the motor.

It will be necessary to power OFF the motor for about 1 minute to reinitialize and to check if the rotor is rotating freely.

Too low load condition:

The motor-fan is configured according to all the range of load the product is expected to work with. In case the load should be abnormally low considering the instant speed, the electronic driver will go into a safety mode. It will be necessary to power OFF the motor for about 1 minute to reinitialize and to check if the rotor is rotating freely.

Thermal protection:

The electronic driver temperature is constantly monitored to protect the motor from over temperature condition.

In case of temperature exceeding 75°, the speed is decreased.

In case of temperature exceeding 80°, the motor is stopped and will run again only when the temperature comes back below 60°C.

Low voltage control interface:

Always connect the 'GND' signal (black wire) before the '0-10V / PWM' signal (yellow wire) or disconnect this Control signal before disconnecting the 'GND'.

The product is dedicated to be connected to earth. Besides security reason, connecting device to the low voltage interface without the PE may cause damages to the electronic.